



MACHAKOS UNIVERSITY

University Examinations for 2022/2023

SCHOOL OF ENGINEERING AND TECHNOLOGY

DEPARTMENT OF MECHANICAL AND MANUFACTURING ENGINEERING

FIFTH YEAR SECOND SEMESTER EXAMINATIONS FOR

BACHELOR OF SCIENCE (MECHANICAL ENGINEERING)

EMM 513: JIG, TOOL & FIXTURES

DATE:

TIME:

INSTRUCTIONS

- I) This paper contains **FIVE (5)** questions.
- II) Question **ONE** is **COMPULSORY** and carries 30 marks
- III) Answer any other **TWO (2)** questions.

SECTION ONE (COMPULSORY)

QUESTION ONE (30 MARKS)

- a) Define the following terms as applied in manufacturing using neat sketches;
- Jig. (3 marks)
 - Fixture. (3 marks)
- b) Enumerate **EIGHT** advantages of jigs and fixtures in manufacturing processes. (4 marks)
- c) Describe **FIVE** principles of location as applied in jigs and fixtures. (10 marks)
- d) Explain the design principles for drill bushings. (6 marks)
- e) Determine the angular accuracy of location if a diamond pin with 4 mm land is used for locating axis of 2 - $\Phi 32$ H7 holes and centre distances between the holes (as shown in Fig 1d) is 200 ± 0.2 . (4 marks)

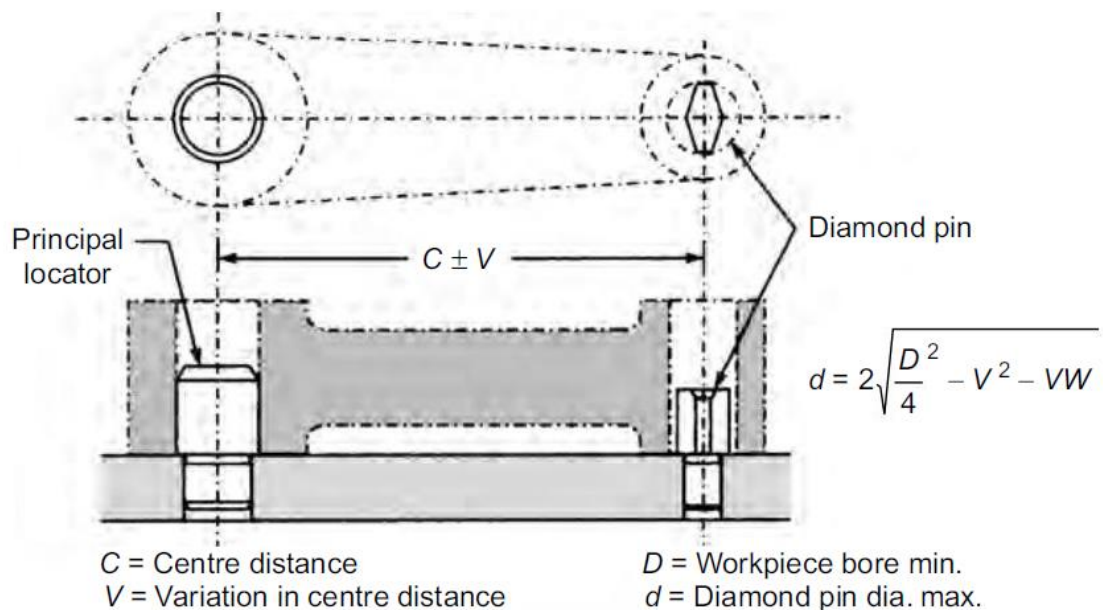

Fig. 1d

QUESTION TWO (20 MARKS)

- a) List **SIX** main components or elements of jigs and fixtures (6 marks)
- b) Enumerate **FOUR** differences between jigs and fixtures. (4 marks)
- c) Highlight **FOUR** classifications of jigs and fixtures. (4 marks)
- d) Design and draw drilling jig for drilling the holes in the component shown in Fig. 2d. (6 marks)

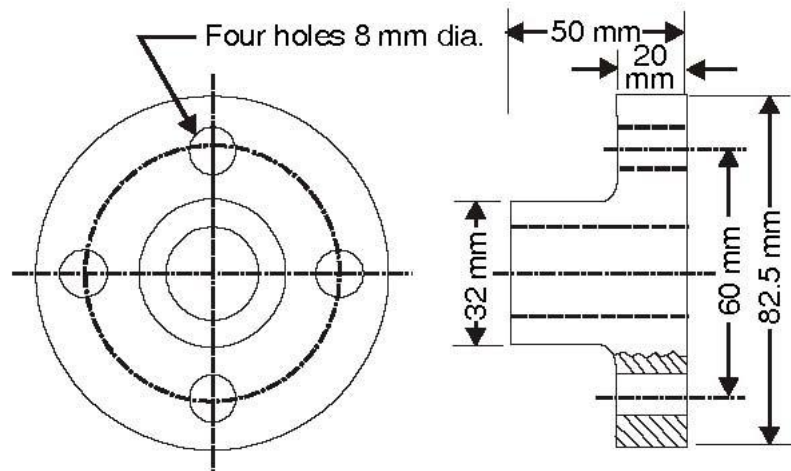

Fig 2d

QUESTION THREE (20 MARKS)

- a) List **THREE** methods used in classification of milling fixtures, giving **TWO** examples in each case. (6 marks)
- b) Using a neat sketch, design and explain elements of an inspection fixture to be used to hold the workpiece in Fig. 3b. (6 marks)

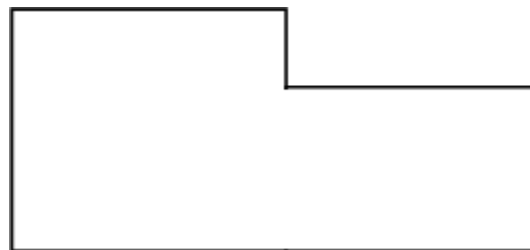

Fig. 3 b

- c) Enumerate **FOUR** features considered in design of lathe fixtures. (4 marks)
- d) What are the functions of broaching fixtures; (4 marks)

QUESTION FOUR

- a) Using neat sketches, illustrate the following types of drilling jigs. (6 marks)
- i. Channel Jig.
 - ii. Leaf Jig.
- b) Enumerate **FOUR** locating devices used in jigs and fixtures. (4 marks)
- c) Discuss **SIX** principles considered in designing of locating surfaces. (6 marks)
- d) A fixture is used three times in a year by incurring set-up cost of Kes. 20 each time. If the initial investment on the fixture is Kes. 400 and labour saving with the use of fixture per piece is Kes. 0.10, with overhead charges as 50% of labour saved per piece, find out the number of pieces which should be manufactured to earn a 12% profit on the investment. Annual rate of interest on investment is 6%, repairs 10%, fixed charges on insurance and taxes as 5% and depreciation at the rate of 50%. (4 marks)

QUESTION FIVE (20 MARKS)

- a) Using neat sketches, illustrate the following types of clamps. (6 marks)
- i. Solid heel clamp.
 - ii. Loose guided clamp.
- b) Enumerate **FOUR** basic requirements of clamping devices. (4 marks)
- c) Discuss **SIX** design and operational factors considered in ensuring proper and adequate clamping of a workpiece in jigs and fixtures. (6 marks)
- d) A flange-plate adapter costs Kes. 24 per part to mill without a fixture, and costs Kes. 10 per part when a fixture is used. Assuming the fixture costs Kes. 12,800, how much will the fixture save over a production run of 1500 parts. (4 marks)

